

## ANALYSIS OF TECHNOLOGY FOR REDUCTION OF DUST POLLUTION IN COTTON CLEANING INDUSTRIES

**Turgunov D.U., Egamberdiyev A.B.**

Fergana polytechnic institute, graduate student of group M26-22a

E-mail: [azizjonegamberdiyev3979#@gmail.com](mailto:azizjonegamberdiyev3979#@gmail.com)

### ABSTRACT

The main scientific and technical issue of creating a dust collector with small hydraulic resistance and implementing an optimal scheme of dust cleaning based on the acceleration of the device for capturing dust from the air in cotton gins and light industrial enterprises is studied in the following article.

**Key words:** cotton, cyclone, device, air, fiber, industry, pneumatic transport, gin.

### INTRODUCTION

One-stage air purification method is mainly used in cotton ginning factories and light industrial enterprises of our republic. Cyclones of various constructions are used as dust collection devices, and their air cleaning efficiency is low and cannot fully meet modern environmental requirements. The degree of air purification with the help of cyclones is in the range of 54.5/86.6. In addition, the scheme of two-stage devices with different compositions is proposed. This causes the energy resources to be over-consumed. The practical application of various variants of two-stage devices shows that installing a VZP-type air cleaner or a small-diameter cyclone device in their second stage will have a significantly higher socio-economic benefit. Therefore, the second stage of the air cleaner is There should be enough favorable conditions to achieve the efficiency of the step. Based on the above, it is advisable to use dust deposition chambers with low energy consumption. However, the level of air purification in cotton ginning enterprises is somewhat lower (50%) due to the low density of fiber dust.

In the technological process of seed cotton processing, in addition to the main products, a large amount of fiber waste is also obtained. Pulp from gins and linters, fluff from cyclones and dust chambers, waste from fiber cleaners and saw drum cleaners constitute fiber waste. The fibers released as a result of the processing of fiber-

containing waste serve as raw materials in the textile industry and in other sectors of the economy. Luk, regenerated (re-separated) cotton fiber is divided into cotton wool.

Gin, fiber cleaner, seed cleaner installed up to the first linter battery, fiber waste from regenerators (when cotton with 1 and 2 types of seed is cleaned) and cleaned of impurities is called fiber pulp. Its composition is different, diseased seeds that have not grown (dead), fiber attached to them, free (unattached) fibers, fibrous waste and various organic and mineral compounds.

If the distance between the gin columns is of the specified size, and the die cam is adjusted in the required position, the amount of dies separated from the gin depends on the type of cotton being processed. 0.2...0.3% of the weight of cotton is used when working with 1st and 2nd grade cotton, and 0.5...0.6% and in some cases 1.5% when working with 3rd and 4th grade cotton. If the spacing between the colostrums of the gin is wider than the specified size, large seeds can also be mixed in the waste. Depending on the type of seed cotton, degree of fiber, dirtiness, moisture and color, the fiber die must be divided into two types according to the requirements. and implementation of an optimal scheme of dust removal is the main scientific and technical issue. This device has the following features:

1. Absence of moving parts in the device;
  2. It is possible to clean dust particles with abrasive properties while the inner part is protected by a special coating;
  3. The device can work up to a high temperature of 500 °C;
  4. The device always has the same hydraulic resistance;
  5. Dust can be cleaned dry;
  6. It is possible to clean dust air even at high pressure;
  7. A simple design was used in the preparation of the device;
- Different fractions of dust can be cleaned. Disadvantage:

1. The difficulty of cleaning when the size of the dust particle is less than 5 μm;
2. Ability to show high hydraulic resistance: 1250-1500 Pa;
3. It is not possible to clean sticky dust.

The main constructions of cyclones are given below: cyclones depending on the method of application. They are divided into helical tangential screw and axially oriented cyclones. Among them, cyclones operating in the axially oriented air supply mode have low cleaning efficiency but low hydraulic resistance. Cyclones widely used in industry include spiral cyclones. But in practice, all cyclones can be used equally.

The principle of operation of cyclones is presented in the diagram below. Air movement in a cyclone:

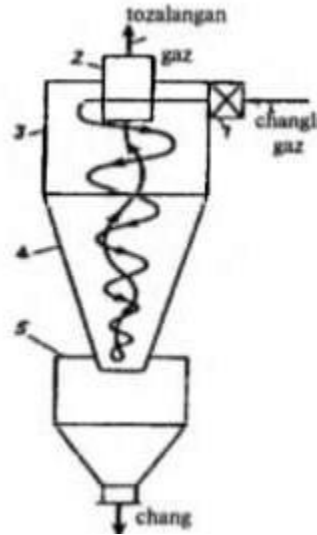

1 - dust air inlet pipe; 2 - exhaust pipe; 3 - cylindrical chamber; 4 - conical chamber; 5 - dust removal chamber.

Dusty air circulates inside the cyclone and moves from top to bottom. In this case, the dust particles in the dusty air are thrown to the edge due to the centrifugal force and hit the wall of the cyclone and move downwards from the cone part of the cyclone under the influence of gravity. , and is inversely proportional to the diameter. It is considered appropriate to use a cyclone to carry out the process at a high speed and with a small diameter. However, increasing the speed causes small particles to escape into the atmosphere during the cleaning process. Therefore, reducing the diameter of the device to increase the cleaning effect is beneficial. The actual ratio of the height and diameter of the cyclone

$$H/Dts = 2 - 3.$$

In light industry, it is accepted to divide the cyclone into high-efficiency and high-efficiency types. The operation of the first type of cyclones is efficient, but the implementation of the process requires high costs. The second type of cyclones have less hydraulic resistance, but they cannot hold small particles well during the cleaning process. (1) In practice, conical (cone part is longer) and cylindrical (cylinder)

longer) cyclones are widely used. Conical cyclones are high efficiency and cylindrical cyclones are high efficiency. The diameter of cylindrical cyclones does not exceed 2000 mm, and the diameter of conical cyclones does not exceed 3000 mm.

The air purifier is designed to capture and remove large dust particles from the polluted air coming out of the cotton drying and cleaning units of the cotton ginning plants and the cotton and cotton products transfer devices with the help of air pipes.

The body of the device is made of iron tin with a thickness of 1.5 - 2.0 mm in a cylindrical shape, in which there are holes for dusty air inlet (1) and outlet (3), as well as a large dust outlet (4). there are holes.

The device is divided into two sections, each of which is designed for an air consumption of 6 m<sup>3</sup>/s.

The process of extracting large dust particles from the dusty dirty air coming out of the technological machines in the air purifier is as follows.

The dusty air enters the cylindrical device from the inlet pipe of the device and receives a circular motion. Centrifugal force compresses the dust particles to the inner wall of the device, and when the large dust comes to the cross-sectional surface of the casing slot with the help of air, it is separated from the air and exits through the vacuum valve. Air flow is directed from the device with fine dust through the hole to the dust holder.

The main cost-effectiveness of the device comes from saving electricity by 20% and reducing metal by 50%. The efficiency of the device for extracting and capturing large dust particles from dusty air is up to 90%, hydraulic resistance is -450 Pa. The air cleaner is the first stage in two-stage dust collection systems, and the second stage uses a high-efficiency dust collector. As a result, dust capture efficiency of dust collectors increases to 1.5-2.0%.

The amount of dust air that can be supplied to the device is up to 18 m<sup>3</sup> per hour. As a result, it will be possible to supply the device with dusty air coming from all technological machines in the range of the fan.

Main indicators:

- air productivity - up to 18 m<sup>3</sup>/s;
- cleaning efficiency - 98% and higher;
- hydraulic resistance - up to 1730 Pa.

Figure 2. Air purifier with large dust trap

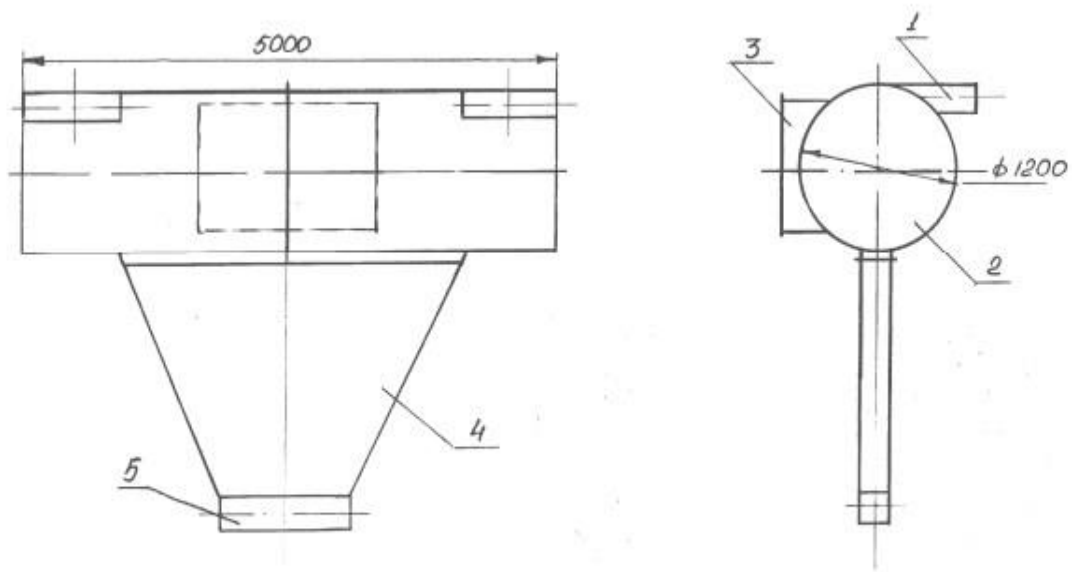

1- dust air inlet; 2- cylindrical part; 3- exit part for powder air; 4- dirty dust discharge part; 5- vacuum valve.

## CONCLUSION

Based on the analysis of the literature, the main scientific and technical issue of creating a dust trap with small hydraulic resistance and implementing an optimal dust cleaning scheme based on the acceleration of the device for capturing dust from the air in cotton ginning factories and light industrial enterprises I studied and analyzed.

## REFERENCES:

1. Fundamentals of industrial waste treatment technology. Musaev M (2011).
2. Design of technological processes. Babadjanov. M.A
3. Usmonov, J. M., Shakirov, S. M., Ubaidullayev, M. M., & Parmonov, S. O. (2021). Aluminum-based composition materials for processing aluminum scrap. *ACADEMICIA: An International Multidisciplinary Research Journal*, 11(8), 590-595.
4. Ubaidullaev, M. M., Shakirov, Sh. M., Usmanov, J. S., & Parmonov, S. T. (2021). Analysis of production technology of carbon graphite materials used in electric motors. *Composite materials*", Tashkent city, 103-107.

5. Kodirov, Z. Z., Iriskulov, F. S., Pulatov, A., & Ubaydullaev, M. (2018). Electronic libraries as a fact of contemporary information landscape. *Economics and society*, (3), 629-633.
6. Bekmirzaev, Sh., Saidmakhamadov, N., & Ubaydullaev, M. (2016). Poluchenia Lite V Peschano-Glinistye Methodom. *Theory and practice of contemporary science*, (6-1), 112-115.
7. Parmonov, S. T., Shakirov, Sh. M., Sharipov, K. A., Ubaidullaev, M. M., & Usmanov, J. M. THE EFFECT OF PLASTICIZERS AND THEIR AMOUNTS ON THE PROCESS OF PRESSING SOLID ALLOY POWDER. In *CONFERENCE-SYMPIOSIUM* (p. 156)